

Northern California Free-mo

HO Scale Free-Form Modular Model Railroading

Module Construction Guidelines

Updated May, 2016

1.0 INTRODUCTION	3
1.1 DEFINITIONS	3
NORCALF or NORCAL FREE-MO	3
MODULE	3
SECTION	3
ENDPLATE	3
FITTER RAILS	3
TRACK POWER BUS	3
ACCESSORY POWER BUS	3
DCC LOCONET BUS	3
DCC BOOSTER COMMONS BUS	3
MSS OCCUPANCY BUS	3
PIGTAIL	3
2.0 FRAME AND LEGS	4
WIDTH, LENGTH, SHAPE	4
ENDPLATES, GENERAL	4
MODULE-TO-MODULE ATTACHMENT	4
SIDES AND FASCIA	4
HANDHOLDS	5
LEGS AND LONGITUDINAL BRACING	5
3.0 TRACK	8
GENERAL	8
SUB-ROADBED	8
ROADBED	8
MAIN TRACK LOCATION	8
MULTIPLE TRACKS CROSSING ENDPLATES	8
RAIL	8
JOINING TRACK BETWEEN MODULES	9
CURVES	10
SUPER-ELEVATION AND GRADES	10
TURNOUTS	10
TRACK RAIL GAPS	10
CLEARANCES	10
4.0 WIRING	11
4.1 TRACK POWER BUS	12
4.2 DCC LOCONET BUS	13
4.3 ACCESSORY POWER BUS	14
4.4 DCC BOOSTER COMMONS BUS	15
4.5 MSS OCCUPANCY BUS	15
5.0 CONTROL	18
6.0 SCENERY	19
SCENERY STYLE, MATERIALS, TECHNIQUES	19
MAIN TRACK BALLAST	19
END PROFILE AND LANDSCAPE	19
INTER-MODULE JOINT TREATMENT	19
BACKDROP	19
7.0 PUBLIC DISPLAYS	19
SKIRTING	19
CROWD CONTROL BARRIER SYSTEM	19
PLEXIGLAS SHIELDS	19
8.0 LOCOMOTIVES AND ROLLING STOCK	20
WHEELS	20
ROLLING QUALITY	20
TRUCKS	20
COUPLERS	20
WEIGHT	20
ELECTRONICS	20
9.0 SETUP CHECKLIST	21
REQUIRED ITEMS	21
RECOMMENDED ITEMS	21
APPENDIX A: LEGACY ELECTRICAL GUIDELINES PRIOR TO JULY 2015	22
APPENDIX B: TUTORIAL FOR VELCRO-ATTACHED VINYL SKIRTING	23
REVISION HISTORY	27

1.0 Introduction

This document clarifies and enhances the general Free-mo standards maintained at <http://www.free-mo.org/standard> for the specific needs and goals of Northern California Free-mo (NorCalF). This guideline is not intended to supersede the general Free-mo standards, which shall take precedence in case of conflict with or contradictions to this document. References to the general Free-mo standard appear in brackets "[S0.00]" throughout this document.

The overarching goal of Northern California Free-mo is to operate finely detailed HO scale standard gauge railroad models in a prototypical fashion through realistic model scenery. Free-mo layouts have a "free-form" configuration that does not readily lend itself to continuous running. Trains originate from one point on the layout, traverse it, and then terminate at the other end (or back at the starting point). This format results in modules that are viewed from both sides [S2.11] and designed to be reversible (can be used in a layout in any orientation).

The Free-mo modular format requires layout end points, typically in the form of stub end yards or reverse loops. A typical Free-mo layout takes the form of an "out-and-back" or a "point-to-point" configuration. Other more complex layouts are possible if "junction" modules are used; for example, a wye module could allow a branch line operation.

Between the end points of the layout are modules that carry the main line from one end to the other. Large modules may be assembled from two or more smaller, easily transportable "sections" to create a large layout feature; for example a passing siding long enough for a full-length freight train could be created as a multi-section module.

1.1 DEFINITIONS

NORCALF or NORCAL FREE-MO

An informal group of like-minded modelers experienced in the various model railroading disciplines. We aspire to a high standard of prototype-based modeling ranging from cabinetry skills for module framing, to preparation and operation of highly detailed locomotives and rolling stock. There is no organizational structure, meetings, or dues. All decisions about setups and group recommendations are made by consensus. Setups occur as space and time are available, typically two to four times per year.

MODULE

Any layout component (or group of "sections") meant to operate as a single unit in a fixed configuration. A module can have any number of sections. All ends of a module must comply with the general Free-mo standards, mechanically and electrically, to accommodate successful mating to adjacent Free-mo modules in a layout.

SECTION

A part of a larger module, complete with bench work, track, scenery, etc. Except where otherwise noted, standards for module end interfaces do not apply to inter-section interfaces, as these are considered to be internal to the module.

ENDPLATE

The standardized end surface of a module that mates to the adjacent module in a Free-mo layout.

FITTER RAILS

The 2" long removable Code 83 rails and joiners used to bridge the joints between adjacent modules or sections (sometimes referred to as "bridge rails" in the context of Free-mo setups).

TRACK POWER BUS

The continuous two wire bus feeding power and DCC commands to the track.

ACCESSORY POWER BUS

The continuous two wire bus powering electrical accessories such as turnout motors, structure lighting, signals, etc.

DCC LOCONET BUS

The continuous six-wire bus carrying control information among the Digitrax DCC system components such as throttles, boosters, radio receivers, etc.

DCC BOOSTER COMMONS BUS

The continuous one-wire bus providing an electrical common for DCC boosters distributed through a layout.

MSS OCCUPANCY BUS

A part of the Modular Signal System (MSS) invented by NorCalF, the continuous eight-wire bus carrying main track occupancy status among modules. While not required by the general Free-mo standard, NorCalF requires this bus to be installed in the modules of group participants.

PIGTAIL

Common name of any of the connector/wire assemblies used to connect the electrical busses together between modules.

2.0 FRAME AND LEGS

Refer to the general Free-mo standard section 2.0 for requirements pertaining to:

- endplate profiles for single and double track modules
- module height (track rail-top height from floor)
- module legs and height adjustment

“Frame work” refers to a module’s structural frame including endplates, sides, interior supports, legs, and braces. There are no requirements to use specific materials or construction methods; however, the basic trade-off is sturdiness versus weight. NorCalF frames have been built from high-quality plywood such as birch, dimensional lumber, and medium-density fiberboard (MDF). Other more exotic materials are possible, but NorCalF has no experience with them as of this writing (wood/foam sandwich, aluminum, honeycomb structures, etc.).

Based on experience, it is recommended to use high ply-count, void-free birch plywood (Baltic birch, Finn birch, multi-ply birch plywood) for the endplates and track sub-roadbed, at a minimum [S2.1]. Dimensional lumber is strongly discouraged due to warping issues. MDF is also strongly discouraged due to weight and breakage issues. Foam board for track sub-roadbed is strongly discouraged due to warping over time.

WIDTH, LENGTH, SHAPE

The General standard specifies only the endplate width [S2.2, S2.3]. Otherwise the module width (and length and shape) are up to the designer. Take into consideration the transport and storage of the module when establishing its overall size and shape. For example, modules over six feet long are difficult to transport and store.

ENDPLATES, GENERAL

Endplates *must* be parallel to each other vertically, and perpendicular to track both vertically and horizontally. They also *must* be flat, i.e. not bowed, twisted, etc. [RP2.1.1]. Material must be solid and sturdy for C-clamping to adjoining modules [S2.1].

Recommended Practices:

- Make endplates from 3/4" high-quality plywood or equivalent stable material to maintain flatness [S2.1]. High ply-count, void-free birch plywood (Baltic birch, Finn birch, multi-ply birch plywood) is recommended. Dimensional pine lumber and MDF are not recommended [RP2.1.1].
- To allow room for C-clamps, recommended clearance area is 2" high by 4" wide, centered at bottom edge of endplate inner surface. In general, leave as much open space as possible on endplate inner surfaces.
- Cut handholds into endplates to assist transporting and positioning the module (see HANDHOLDS, below).
- Painting of endplates is discouraged since it can cause adjoining modules to stick together. However, if painting of endplates is desired, use "flat" Glidden "Great Desert" beige (formula below). Do not use black or other dark colors as this causes module joints to be more visible.

Notes:

- Some legacy modules have more than one track at a 24"-wide endplate. Mating them with 26"-wide double track modules results in small layout fascia offsets.
- Mating 24"-wide single track and 26"-wide double track modules results in small layout fascia offsets.

MODULE-TO-MODULE ATTACHMENT

C-clamps are used at the endplates, positioned near the endplate center (directly below the tracks).

Recommended Practices:

- Use “deep-throat” C-clamps to apply pressure closer to module top and draw track ends together.
- Wide modules with multiple tracks (e.g., yard modules) may be secured with two clamps, one toward each side of the module.

SIDES AND FASCIA

Fascias must be smooth and made of a solid, sturdy material (plywood, hard board, Masonite, etc.) to withstand handling during module transport and layout setup. The 24" or 26" width of the module at its endplates must include fascia thickness on both sides of the module. Color must be Glidden Great Desert beige (formula below).

Recommended Practices:

- Use “semi-gloss” Great Desert to permit easier clean-up of fingerprints and the like.
Note: semi-gloss is more difficult to sand down when preparing to repaint fascias.
- Back thin fascia materials (hard board, Masonite, etc.) with solid frame material (plywood, etc.) all the way

to the bottom edge of the frame, to prevent damage to fascia when module is lifted by its sides.

- Recess fascia-mounted items like turnout controls and throttle panels to prevent accidental damage or injury to operators; avoid protruding items that could be damaged when module is set on its fascia.
- Label electrical switches and other operational items when their function is not obvious. Use black lettering at least 3/8" tall.

Formula for Glidden "Great Desert" beige:

GREAT DESERT (30YY 33/145)				
BASE2 (HM1212)				
GALLON				
COLORANT		OZ	48	96
B	LAMP BLACK	1	6	0
C	YELLOW OXID	1	38	0
F	RED OXIDE	0	6	0
KX	WHITE	7	0	0

HANDHOLDS

Handholds are not required, but are suggested to ease handling modules during transport and setup. On endplates, many NorCalF modules use one centered handhold, or two side-by-side, per the sketch below. Dress the handhold edges to be rounded and smooth to prevent hand injuries from sharp edges, wood splinters, etc.

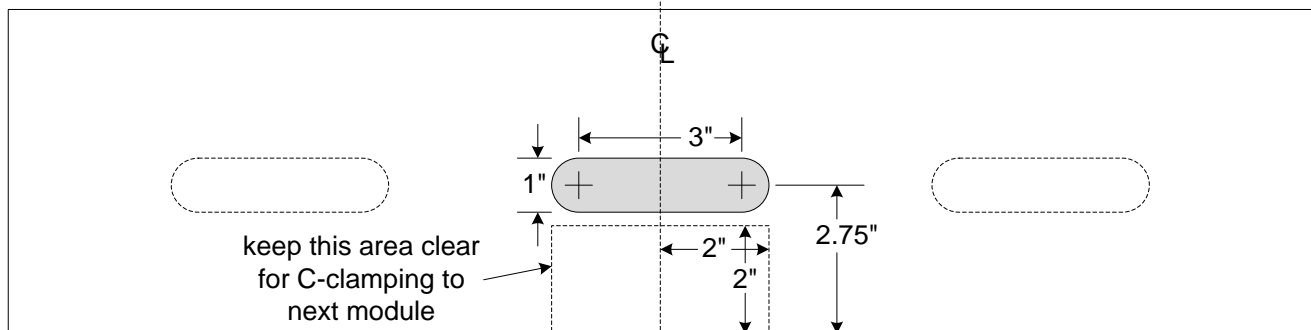

Endplate Handhold Suggestions

LEGS AND LONGITUDINAL BRACING

Signal-mo modules no longer than 12" are exempted from the general requirement to have legs for free-standing independent of other modules [S2.8].

Recommended Practices:

- Provide a larger height adjustment range than the minimum 2" requirement [S2.9]
- Design and construct legs as part of the frame, making them an integral part of a module structure.
- Install cross- and angle-bracing on legs for added module stability. Longitudinal braces reduce module sway parallel to the track, stabilizing the module for fine adjustments during setups.
- Permanently attach legs to module frame and have them fold up for transport, if module size allows. This method allows speedy setup/teardown, simplifies transport and storage, and eliminates loose hardware. The trade-off is increased module weight for transport.
- Painting legs is optional. However, painting or staining the legs black helps hide them during setups.
- Because many setup locations have very uneven floors, 3/8" T-nuts or brackets and 4" leveler feet are recommended. Most NorCalF modules now use the Lee Valley products.
- The Lee Valley 4" leveler feet also help prevent damage to floor surfaces.
- For folding legs, verticals can be 1x2 and the angle brace omitted to permit nesting of the folded legs. The resulting legs will not be as sturdy without the brace, but experience has shown that stability is adequate.

Suggested Module Leg Construction:

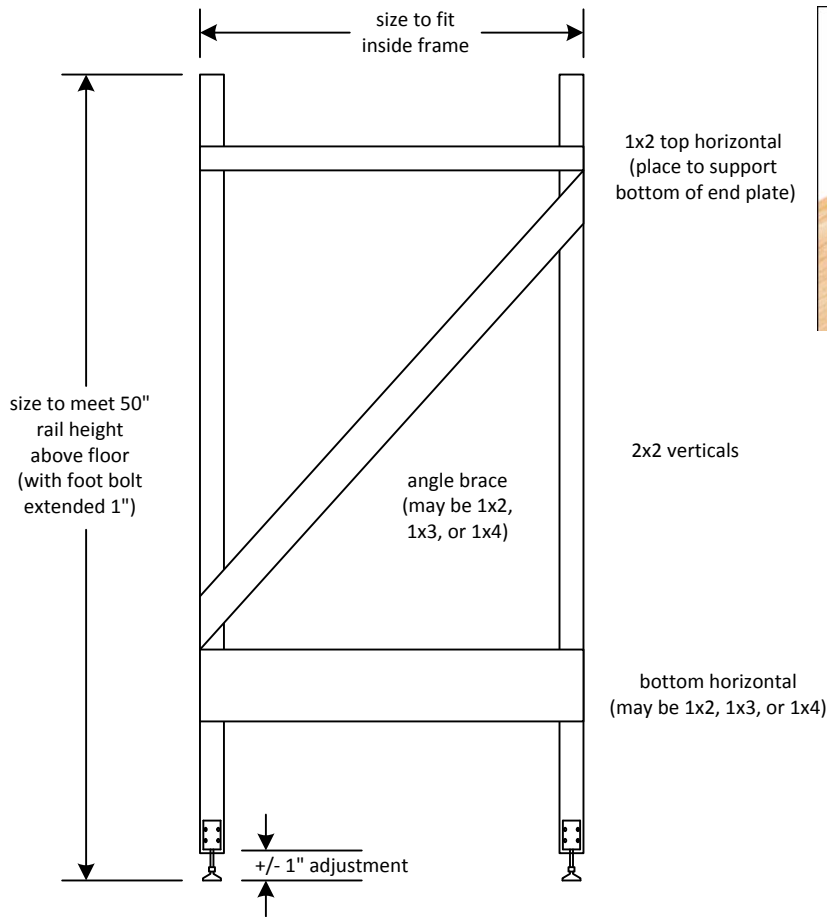

One possible leg design using dimensional lumber.
Lee Valley leveler feet and brackets mounted at the bottom for height-adjustment.



Visit Lee Valley Hardware at www.leevalley.com/hardware/

Folding brackets like these from Lee Valley (#00T16.01) can be used to build permanently attached fold-up legs. They lock into position both open and closed.

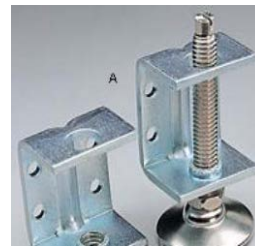

Another option for height-adjustment hardware. Lee Valley #01S04.05 bracket and #01S06.04 (4" tall) leveler feet. These can be adjusted with a screwdriver from above, avoiding crawling around on the floor during setups.

These views of the NorCalF Mojave yard illustrate the use of folding legs.

Legs folded up for transportation:

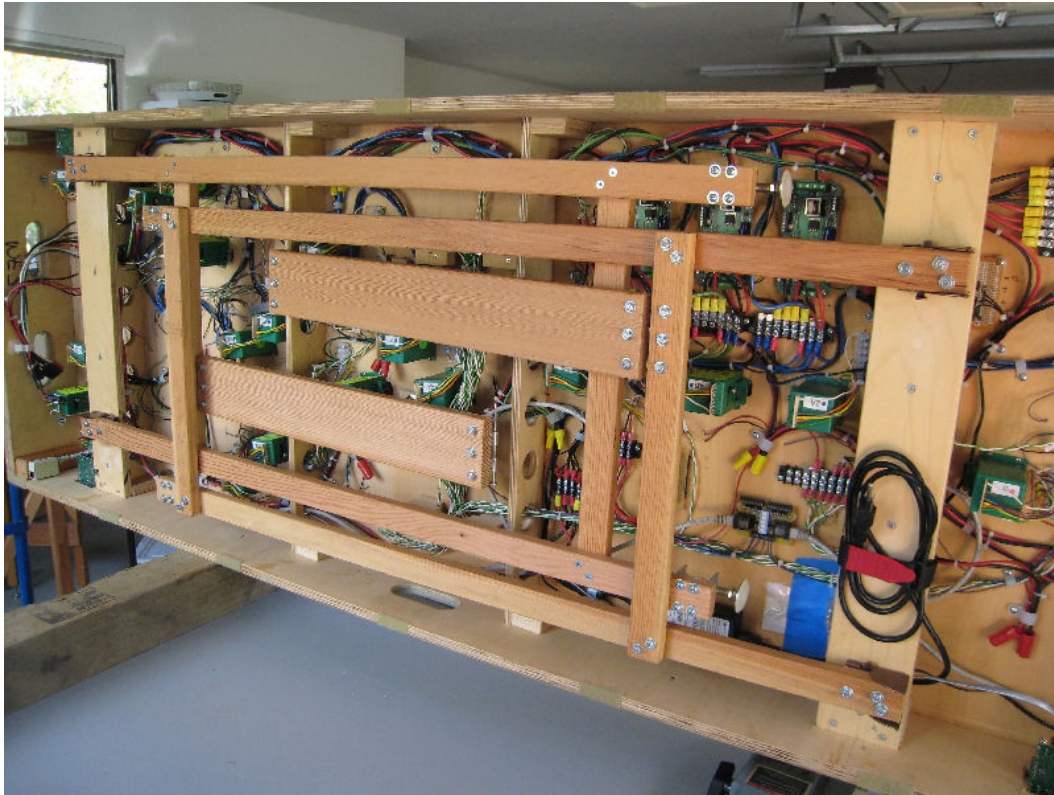

Legs deployed, ready for standing up:



3.0 TRACK

Refer to the general Free-mo standard section 3.0 for requirements pertaining to:

- type of model track and rail size
- track location and spacing within the module and at the endplates, including single- and double main track modules
- rail setback from endplates, including tie and ballast treatment, and fitter rail accommodations
- curve radius, turnouts, reverse curves, grades

GENERAL

Take full advantage of this comprehensive resource regarding track work for Free-mo modules:

http://garymgreen.com/handbook_introduction.html

All NMRA standards must be met [S3.13, S3.15]. All track and turnouts must pass all tests using the NMRA Mark IV track gauge (rail gauge, flange ways, etc.).

Track *must* be perpendicular to the endplate both horizontally and vertically [S3.6].

SUB-ROADBED

Sub-roadbed construction and materials must prevent sagging or flexing, and must be installed to comply with the endplate requirements. Be particularly careful that the sub-roadbed remains flat all the way to the endplates (e.g. does not slope), and is vertically perpendicular with the endplates.

Recommended Practices:

- To date, NorCalF modules have used plywood or foam insulation board. The main trade-off is rigidity/stability versus weight.
- It is recommended to use 5/8" to 3/4" high-ply-count plywood sub-roadbed under track locations, well supported from the sides of the module to prevent sagging or bowing.
- Foam board is discouraged because it has proven unstable over time and difficult to glue permanently in place. However if foam board is used, provide supports either parallel or perpendicular to the track to provide maximum support for the foam, resulting in a flat track profile. Consider locations where access to the track from underneath the module (e.g., for a switch machine) will be required.
- Homasote should be sealed thoroughly on all surfaces before installation because it is susceptible to humidity changes.

ROADBED

Refer to general standard [S2.4]. Roadbed must comply with the standard 3/8" dimension from top-of-scenery to rail-top [S6.3]. This requirement is to ensure scenic profiles flow smoothly across module-to-module joints, thereby minimizing abrupt scenic discontinuities within a layout.

Note: Standard HO scale cork roadbed used under flex track meets the 3/8" requirement.

MAIN TRACK LOCATION

Failure to meet the requirement that track be perpendicular vertically to the endplate without a twist of any kind is the most common issue when aligning modules at setups and the most common cause of derailments during operations.

Note: Track spacing may exceed 2" centers within a module, e.g. wider spacing through curves [S3.13].

MULTIPLE TRACKS CROSSING ENDPLATES

All tracks in addition to the main track(s) that cross a Free-mo endplate must be centered at 2" increments from the main track(s), and must extend at least 6" from the endplate. An example is a multi-track yard.

Rail tops of all tracks at the endplate must be at the same height as the main track(s). This is to accommodate the reversibility of the module. An example is a passing siding adjacent to a main track.

RAIL

All active rails must have clear flangeways.

All active rails must be easily cleanable..

Recommended Practice: keep the rail tops slightly higher than adjacent scenic elements like grade crossings, such that the adjacent scenery does not interfere with, and is not damaged by, the rail cleaning process.

Rail cleaning with an abrasive cleaning block and/or isopropyl alcohol is permitted. Other rail cleaning materials, methods,

or treatments shall not be used so as to prevent contamination of others' modules. Cleaning rail on someone else's module is allowed only after obtaining the permission of the module owner and using only the method approved by the module owner.

JOINING TRACK BETWEEN MODULES

This illustrates how the 2" fitter rails are installed across module joints in a layout:

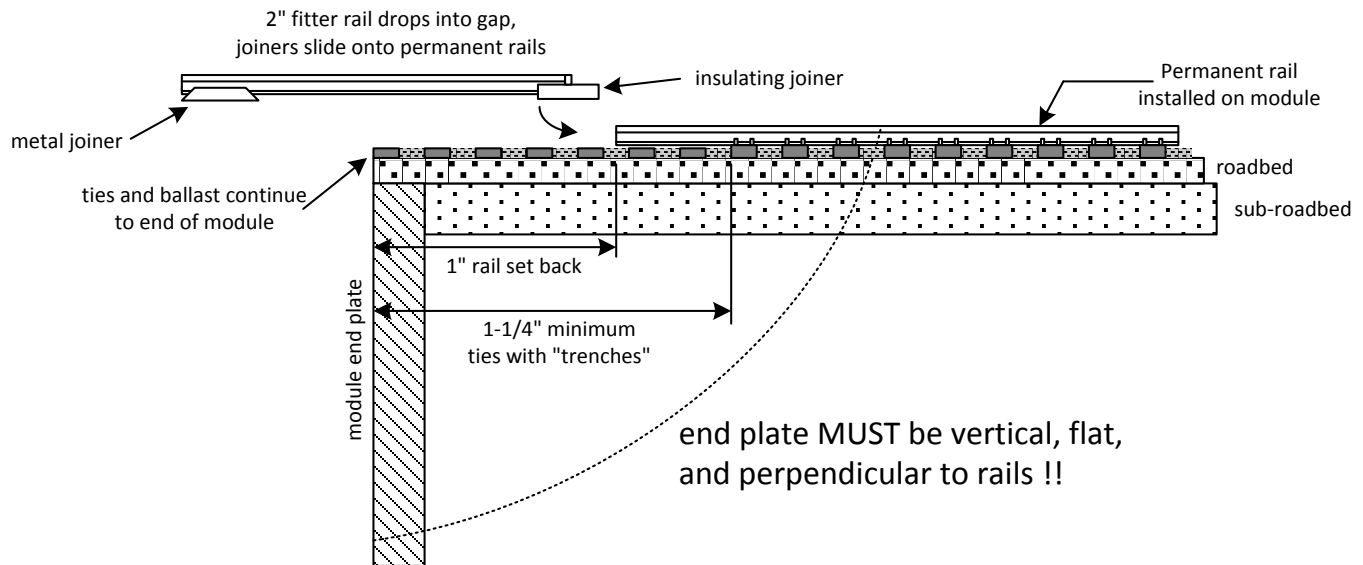

One insulating joiner and one conducting metal joiner must be used on each fitter rail in the following situations:

- Main tracks that have detection to support signal operations, e.g. Modular Signal System (MSS),
- All tracks crossing a DCC track power district boundary [RP3.7.1].

Otherwise, two metal joiners on each fitter rail may be used (e.g. undetected tracks not crossing a DCC track power district boundary).

Recommended Practices:

- The various manufacturer's Code 83 rail and joiners have different cross section profiles; some are larger, while others are smaller. Wherever possible, use fitter rail and joiner profiles that match the permanent rails on the adjoining modules. Choose the brand and size metal joiners that hold the fitter rail firmly in place such that it does not wobble, lean to the side, or introduce significant rail top height differences.
- Do not use Walthers Code 83 metal joiners. Their cross sectional shape does not provide a good surface to push them into place.
- Do not use N-scale metal joiners. For rails with smaller profile, use the matching small profile Code 83 joiner (for example, use Micro Engineering Code 83 joiners with Micro Engineering rail).
- When the two modules' fixed rails are of mixed profile (e.g. larger profile rail on one module and smaller profile rail on the other), use a fitter rail and joiner with the larger profile and place the metal joiner on the end that mates to the module with the larger rail profile.
- Use Code 83 insulating joiners. However, Code100 insulating joiners may be used but require trimming down the center insulating divider so it does not project above the rail top.
- Avoid rail gaps larger than 3/64" (~ 1mm). Use a longer fitter rail to alleviate such a large gap.
- Before attempting fitter rail installation, slide the selected metal joiner back and forth along the fitter rail to ensure the joiner moves freely enough to slide onto the module's rail, yet is not so loose that it cannot hold the fitter rail securely.
- Before sliding the joiners into place onto the module's fixed rail ends, verify the tie trenches will accommodate the rail joiners [RP3.7.1, RP3.7.3]. If obstructions are present, work with the module owner to clear the tie trenches for the joiners to fit.
- To help visually blend in the fitter rails, use weathered rail stock or paint them, including joiners.

CURVES

30" is the minimum radius for branch lines, industry spurs, and similar non-through secondary tracks.

All main track curves should include easements. Articles for creating easements can be found on the Internet at:

<http://jglrr.com/engineering/software/spiral/index.html>

<http://home.comcast.net/~daletherail/curve/curveHome.html>

Recommended Practices:

- Use 48" radius or more whenever possible. The 42" radius is the main track minimum, but larger radius looks and operates better!
- For spurs, service tracks, and similar secondary tracks, consider the type of equipment that will potentially attempt to operate over such tracks during a typical Free-mo setup. For example, if a large steam engine tries to use an engine servicing track, it may require a larger curve radius than the 30" minimum.

SUPER-ELEVATION AND GRADES

Super-elevation of main track curves, vertical track curves, and grades are permitted [S3.14], appropriate for main track operation of contemporary long cars (for example, 90' cars must be able to negotiate these track profiles without derailing or uncoupling from adjacent cars).

Recommended Practices:

- When constructing track that includes vertical curves as described above, use a straight edge of at least 12" laid on top of the rail to measure the rate of change of the rail height. Measure each rail separately. The space between rail top and straight edge should not exceed 1/16" within 12" of horizontal run.
- To super-elevate track, the outside rail is raised.
- The transition from flat to super-elevated track must be very long in order to prevent derailments of long cars and engines. A good guideline is to make the transition twice the length of the longest cars to be operated on the track (for example, 24" long for 90' cars).
- The transition should run from the start of the fixed radius curve through the easement and onto the tangent (straight) track as required. Super-elevation should be constant through the fixed radius curve.
- Super-elevation is often modeled at an overly extreme height. Elevation of the outside rail by just 1/32" would be quite prototypical.

Note: Grades are possible within a large module, as long as nominal rail-top height is 50" from floor at both endplates of the module. The general Free-mo standards have a provision for grades across multiple modules [S2.6, S2.7, S3.1], but for simplicity NorCalF does not allow this until further notice.

TURNOUTS

Minimum #5 frog for branch, industrial, and similar non-through-route tracks. Otherwise, comply with the general Free-mo standard [S3.8].

Point throw must reliably and completely close the point rails against the stock rails.

Frogs must be power-routed from stock rails. Avoid relying on the contact between point and stock rails to conduct power through points into the frog [S4.10].

Recommended Practices:

- Use DCC friendly turnout points to prevent point-to-stock rail short circuits.
- Use an NMRA track gauge to verify all flange ways, etc. meet NMRA standards; correct as needed.

Notes:

- Some older modules have through-route turnout points located within the 6" straight at the module endplate, in violation of [RP3.6.1]. For new modules, adhere to [RP3.6.1].
- Some older modules have through-route turnouts less than #8, in violation of [RP3.8.1]. For new modules, adhere to [RP3.8.1].

TRACK RAIL GAPS

Both rails to all siding and spur tracks must be gapped from the main track rails, for full electrical isolation to ensure main track current detectors are not affected by trains on side tracks.

On Modular Signal System Cascade modules (that define the boundary between two signal blocks), both rails of the detected track(s) must be gapped at the signal block boundary to electrically isolate current detectors on the two blocks.

CLEARANCES

All clearances (curves, tunnels, structures, etc.) must meet NMRA standards.

Note: potentially every type of rolling stock will run over all modules, requiring all clearances to accommodate the tallest double stack, longest piggyback flat, prototypically articulated steam engines, etc.

4.0 WIRING

Refer to the general Free-mo standard section 4.0 for requirements pertaining to:

- Electrical busses for Track Power, DCC LocoNet, Accessory Power, DCC Booster Common
- Wire gauges
- Module-to-module pigtails and connectors (electrical and mechanical)
- DCC throttle panels

For NorCalF modules, five simple electrical busses run through each module and connect them together. Each bus uses a unique connector configuration to prevent accidental misconnection between modules.

The first four busses comply to the general Free-mo standard [S4.1]:

- Track Power bus routes DCC power to the track for running trains
- DCC LocoNet bus interconnects DCC layout control hardware (throttle panels, radio receivers, etc.)
- Accessory Power bus routes power for accessories (turnout motors, structure lights, signal system, etc.)
- Booster Common bus provides an electrical commons for DCC boosters.

The fifth bus is not required by the general Free-mo standard, but is required for NorCalF modules:

- MSS Occupancy bus carries main track occupancy information in support of the Modular Signal System.

Recommended Practices:

- Construct wiring and electrical hardware to be "modular" for easy debugging, repair, and modification; e.g. use terminal blocks and connectors wherever possible, attach using screws or Velcro instead of glue, avoid permanent connections such as soldering, one-time use connectors, etc.
- Leave some extra length in wire runs. Avoid taut wire connections as they can break loose during transport and handling.
- Add strain relief and service loops to wires near their connections.
- Keep wiring as accessible as possible for easy repair or modification. Avoid burying wiring in the frame work or scenery.
- Use insulated wire to prevent inadvertent short circuits or electrical shocks. Avoid using bare wire.
- Follow a wire color coding scheme to assist in debugging, etc.
- Tie all wiring to module frame to prevent damage during transport and setup, especially near endplates where C-clamping occurs.
- Document the module's wiring (e.g. a schematic connection diagram, the meaning of the wire color coding, etc.) for reference when debugging, repairing, modifying, etc. This can avoid the frustration of reverse-engineering a rat's nest of wiring.
- Prepare spare sub-assemblies, electronic boards, etc. and bring them to Free-mo setups in case the module needs to be repaired during a setup.

4.1 TRACK POWER BUS

This illustrates typical wiring within a module for the Track Power Bus:

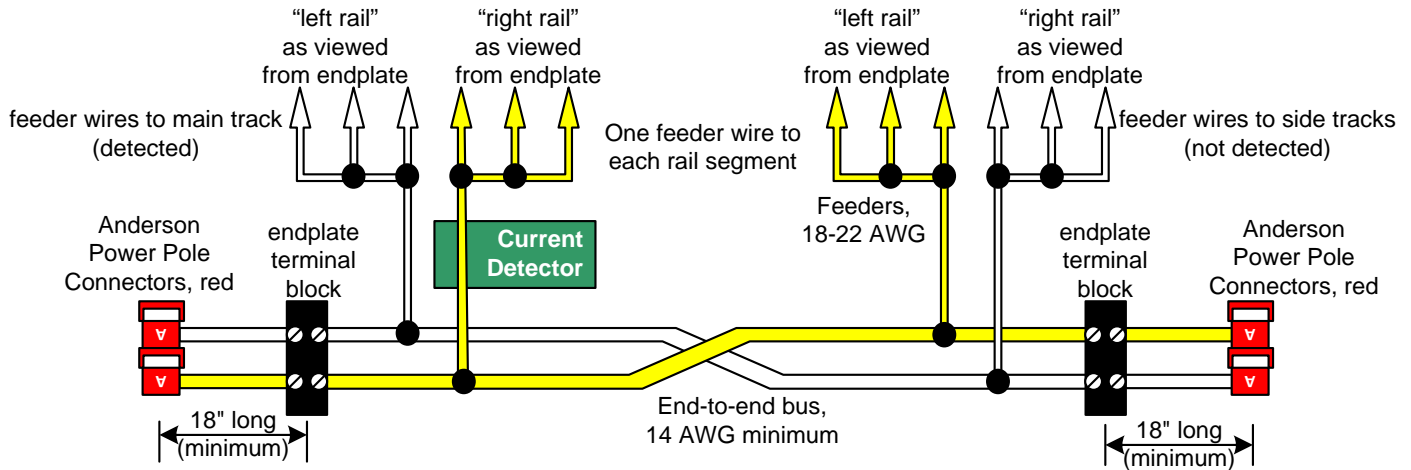

Free-mo requires a continuous Track Power Bus wire pair running "end-to-end" between the module endplates.

Each endplate of every module has a "pigtail" connection for mating to the adjoining module. The pigtails are cross-wired from end to end, allowing a module to be rotated (reversed) and still maintain correct track polarity. See the general Free-mo standard S4.5 for connector mechanical and electrical requirements.

NorCalF requires the pigtail length of 18" be measured from the point it crosses the endplate, such that there is at least 18" of pigtail length beyond the endplate face. This ensures pigtails will reach for mating regardless of where they are mounted side-to-side in the module.

NorCalF requires red PowerPole connector housings for the Track Power Bus.

The Track Power Bus connectors are left disconnected at DCC power district boundaries in a layout.

Recommended Practices:

- Define "directions" for a module, e.g. North/East/South/West, to use as orientation keys during wiring.
- Install a terminal strip at each module endplate. Connect the internal Track Power Bus wires to one side and the pigtails to the other side [S4.4]. This terminal strip can be shared with the Accessory Power and DCC Booster Commons bus pigtails.
- Connect a power feeder wire to each segment of rail. This method avoids relying on rail joiners to carry power from one rail segment to the next, and allows the bus to carry high currents throughout the layout with minimal voltage drop.

NorCalF requires all modules to have current detection on the main track(s), in support of the Modular Signal System:

- Only one rail of each main track requires current detection. Do not place current detectors on both rails.
- Structure rail feeder taps from the Track Power Bus so that all current to the main track rail passes through a current detector, and no current to side track rails passes through the current detector.
- When multiple feeders to the main track rail are necessary, create a separate internal bus wire that is first passed through the current detector from the Track Power Bus, and then fans out to the multiple connections to the main track rail.
- MSS Cross-over modules require at least one current detector, for detecting the full length of the main track on the module. MSS Cascade modules require at least two current detectors, one on each side of the signal block boundary (where both main rails are gapped).
- For double main track modules, provide a way to easily select which track is detected, since Free-mo layouts typically support only a single detected main track. Possible solutions include:
 - a heavy-duty DPDT switch for selecting which rail feeder passes through the current detector,
 - internal swappable rail feeder connections for routing a given rail feeder through the detector,
 - two current detectors, one per main track, whose outputs feed two parallel MSS Occupancy Buses.

Note: For legacy Track Power Bus information prior to July 2015, refer to Appendix A.

4.2 DCC LOCONET BUS

Free-mo requires a continuous 6-conductor DCC LocoNet Bus cable running "end-to-end" between the module endplates.

NorCalF modules less than four feet long are not required to have LocoNet throttle panels [S4.12, RP4.12.2]. However, experience at many setups has shown there can never be too many panels.

While NorCalF has used commercially available wall-mount style RJ12 phone panels in the past, DCC-specific throttle panels are now strongly recommended for robustness and ease of system debugging. Digitrax and North Coast Engineering (NCE) make DCC-specific throttle panels that allow fully modular LocoNet wiring (e.g. RJ12 clip-plugs crimped on flat 6-conductor phone cable).

All LocoNet throttle panels must be mounted such that the throttle's RJ12 plug retainer clip is oriented on the top when plugged into the panel. Refer to the illustration, below.

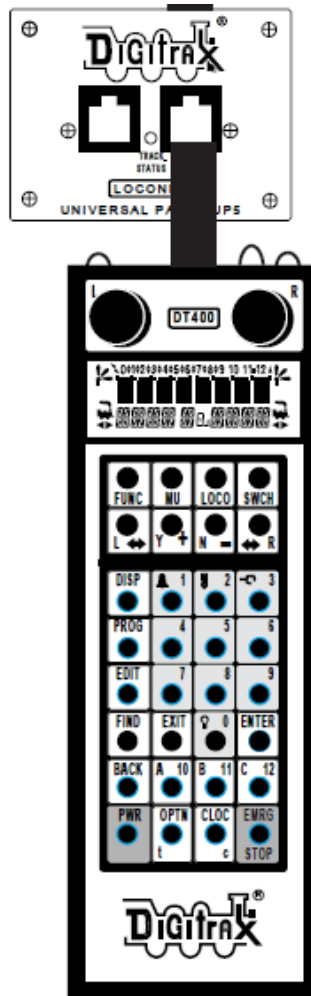

Wire all RJ12 jacks in a series "daisy-chain" fashion to minimize branches in the LocoNet network. Make sure all LocoNet cables are wired "straight through" [S4.13].

WARNING: commercially available prefabricated telephone cables or cords cannot be used because they are not wired straight through!

Do not tap into the Track Power Bus to power throttle panel lighting or supplement LocoNet power. Instead, use the Accessory Bus with the appropriate AC to DC rectifier or a stand-alone power source.

Recommended Practices:

- Verify that each cable segment of the LocoNet bus is properly constructed before installing it into the module. Use an appropriate RJ12 cable tester to confirm all six conductors have continuity through the cable in a straight-through pattern [S4.13].
- Use Velcro or some other non-permanent attachment method to mount the required RJ12 female-female coupler inside each module endplate [S4.7]. Avoid gluing the couplers permanently in place. This method

allows inspection, repair, and replacement of the coupler.

- Use 36" long cables for linking the LocoNet bus between modules to ensure they have adequate reach (note: this is longer than the 24" length in the general Free-mo standard [S4.14]).
- Before each setup, inspect all RJ12 jacks, especially throttle jacks and endplate coupler jacks, for damage to the embedded wiper contacts, and repair as needed. These bare-wire contacts can be damaged (bent, skewed, flattened, twisted, etc.) and cause DCC system problems if a cable is inadvertently mis-connected during setup or an operator mis-connects a throttle.

4.3 ACCESSORY POWER BUS

This illustrates typical wiring within a module for the Accessory Power Bus:

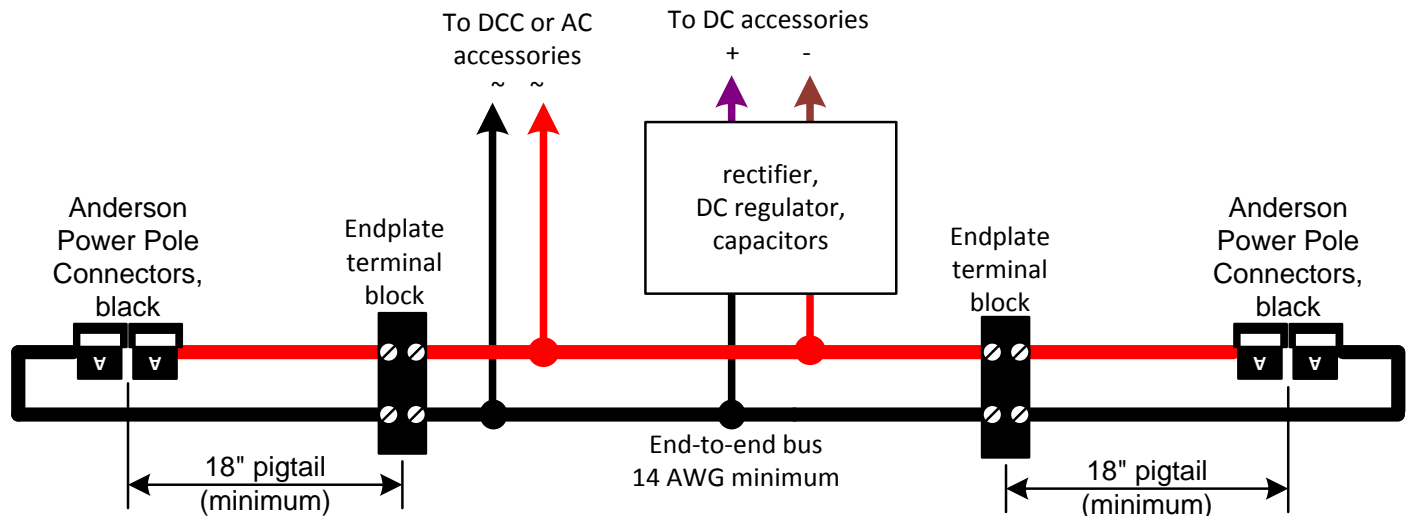

Free-mo requires a continuous Accessory Power Bus wire pair running "end-to-end" between the module endplates.

The Accessory Power Bus normally carries DCC [S4.11], similar to that carried by the Track Power bus, and is often powered by a dedicated DCC booster. The booster may be synced to the Track Power DCC boosters as needed by the specific Free-mo layout (e.g. if DCC stationary decoders are present).

Alternately, the Accessory Bus may carry 14-16V alternating current (AC) [S4.11].

Electrical accessories within modules may use the DCC power directly (e.g. to control and power stationary decoders), or rectify and regulate it to DC (e.g. to power lights or electronics). When 14-16V AC is on this bus, it may be used directly or may be rectified and regulated to DC as well [S4.11].

Suggestion: Use a commercial AC-to-DC power supply, or construct one using a bridge rectifier with an adequate current rating such as Digi-Key KBP2005GDI-ND, a 12VDC low-dropout type regulator such as Digi-Key LM2940CT-12/NOPB-ND, and filtering capacitors such as Digi-Key P5167-ND.

Each endplate of every module has a "pigtail" connection for mating to the adjoining module. See the general Free-mo standard S4.5 for connector mechanical and electrical requirements.

NorCalF requires the pigtail length of 18" be measured from the point it crosses the endplate, such that there is at least 18" of pigtail length beyond the endplate face. This ensures pigtails will reach for mating regardless of how they are terminated in the module.

NorCalF requires black PowerPole connector housings for the Accessory Power Bus.

The Accessory Power Bus connectors are left disconnected at Accessory Bus power district boundaries in a layout.

Recommended Practices:

- Install a terminal strip at each module endplate. Connect the internal Accessory Power Bus wires to one side and the pigtails to the other side [S4.4]. This terminal strip can be shared with the Track Power and DCC Booster Commons bus pigtails.
- Verify all electrical hardware (including bridge rectifiers and other power-conversion circuits) connected to the Accessory Power bus can safely function with DCC and 16VAC for input power. Note: many turnout motors (e.g. Circuitron Tortoise) cannot use DCC or AC power! They require the Accessory Power Bus to be rectified and regulated to DC.

Note: For legacy Accessory Power Bus information prior to July 2015, refer to Appendix A.

4.4 DCC BOOSTER COMMONS BUS

Free-mo requires a single 14AWG stranded wire running "end-to-end" between the endplates, with pigtail connectors for mating across module joints. Refer to the general Free-mo standard RP4.1, S4.16, S4.17, S4.18.

This bus provides an electrical commons for DCC boosters when distributed through a Free-mo layout. Modules do not make any electrical connections to this bus.

NorCalF requires the pigtail length of 18" be measured from the point it crosses the endplate, such that there is at least 18" of pigtail length beyond the endplate face. This ensures pigtails will reach for mating regardless of how they are terminated in the module.

NorCalF requires brown PowerPole connector housings for the DCC Booster Commons bus.

Recommended Practices:

- Install a terminal strip at each module endplate. Connect the internal DCC Booster Commons Bus wire to one side and the pigtails to the other side [S4.4]. This terminal strip can be shared with the Track Power and Accessory Power bus pigtails.

4.5 MSS OCCUPANCY BUS

This bus is part of the Modular Signal System (MSS) developed by and adopted as standard practice by NorCalF.

The MSS Occupancy Bus carries main track occupancy status among modules for the purpose of animating trackside signals in a realistic sequence as trains move over the layout. Though not required by the general Free-mo standard, MSS is a required feature of NorCalF modules and is strongly encouraged in "visiting" modules included in NorCalF-organized layouts. For more detailed MSS information visit <http://www.modularsignalsystem.info/index.html>

The bus is constructed from commercially available 8-conductor CAT5 "Ethernet" network cables and 8-position RJ45 straight-through couplers. Two types of cables are used, depending on a module's role in the signal system and the specific implementation of the bus wiring within a module:

- **Crossover cable** has a built-in wire pattern in which two wire pairs change pin positions from one end to the other, and the other two wire pairs connect straight through. NorCalF standard is yellow cable jacket, although other "warm" colors are acceptable (orange, red, pink, or white).
- **Patch cable** wire pattern connects all eight wires straight through from one end to the other. NorCalF standard is blue cable jacket, although other "cool" colors are acceptable (green, violet, gray, or black).

All modules require an 8-position RJ45 straight through female-female coupler mounted inside each endplate. The module's internal bus cabling is plugged into one side of each coupler, while the other side of each coupler is left open (this is very similar to how the DCC LocoNet bus is implemented).

The bus is connected across each module joint using a CAT5 crossover cable, minimum 36" long, plugged into the open side of each module's endplate RJ45 coupler. Therefore each module must provide one of these cables at NorCalF setups.

The internal implementation of this bus within a module depends on that module's role in the MSS, as follows:

- **MSS Crossover Node module:** This is the most common module type and does not have trackside signals, forming part of the central portion of a signal block. Its MSS Occupancy Bus must have an odd number of crossover wire patterns between its endplate RJ45 couplers (most MSS Crossover Node modules have just one crossover, implemented by a CAT5 crossover cable).
- **MSS Cascade Node module:** This module type typically has trackside signals (though not absolutely required) and acts as the boundary point between two signal blocks (i.e. these modules define the ends of signal blocks). Its MSS Occupancy Bus must have a special MSS wire pattern called a "Cascade element", which requires custom wiring to implement (i.e. this wire pattern is not available in commercial CAT5 cables). MSS Cascade Node modules must not have any crossover wire patterns between endplates; this implies the wiring is straight through between the Cascade element and each endplate RJ45 coupler (CAT5 patch cables are typically used).

Note: The "Occupancy Bus Utility Board" (OBUB) can be used for implementing either MSS Crossover or Cascade wiring elements, and provides connectivity to simplify module internal wiring tasks.

All modules are required to have train detection circuits, which send the module's "local" main track occupancy status into

the MSS Occupancy Bus. Two types of detectors are used – current detectors and infrared (sometimes called ‘optical’) detectors. In general, current detectors are required in all modules, while infrared detectors are required in MSS Cascade Node modules but are optional in MSS Crossover Node modules.

All detectors regardless of type must have open-collector, active low outputs. Each detector’s output must connect to the solid blue wire (pin 4) in the MSS Occupancy Bus CAT5 cable within the module (the solid blue wire carries “local” occupancy status).

In MSS Cascade Node modules, note there are two “solid blue” wires, one on either side of the cascade wire pattern, that do not connect to each other. Take care to properly connect detector outputs to affect the appropriate signal block’s blue wire (CAT5 cable pin 4).

Each detector’s ground reference must connect to the white/blue (pin 5) wire in the MSS Occupancy Bus CAT5 cable within the module (this wire is the MSS Ground, the common ground reference throughout the MSS). The 12VDC power source for signal system electronics also must be grounded to this wire.

Notes:

- The original, "V1.0" MSS used CAT5 cable pins 5, 7, and 8 for the MSS Ground. However, the current V2.0 MSS Standard specifies pin 5 as always used for MSS Ground, pin 7 as default for MSS Ground with an option for use by alternate functions, and pin 8 as always used for Approach Diverging status.
- For modules previously built with MSS Occupancy Bus pin 7 and/or 8 tied to MSS Ground on pin 5, it is strongly recommended to upgrade the wiring to MSS V2.0 as follows:
 - In all modules, separate pin 8 (solid brown) from pins 5 (white/blue) and from pin 7 (white/brown).
 - In all modules, connect pin 7 (white/brown) to MSS Ground on pin 5 (white/blue) through an SPST switch or a removable jumper.
 - In MSS Crossover Node modules, connect the pin 8 (solid brown) straight through from endplate to endplate – do not connect it to anything else within the module.
 - In MSS Cascade Node modules, terminate the pin 8 (solid brown) wires from each endplate such that they do not connect to each other – these wires may then be monitored by signals to display Approach Diverging indications.

Recommended Practices:

- Follow the general wiring recommended practices at the beginning of this guideline section.
- For current detection, NorCalF has successfully used the DCC Optimized Detector (DCCOD, developed by Bruce Chubb) in all types of modules (e.g. endpoint modules and mainline modules), and North Coast Engineering (NCE) BD20 current detectors in mainline modules (both Crossover and Cascade) where moving trains draw higher track current. There is also a promising new line of MSS detectors coming from Iowa Scaled Engineering. The DCCOD has a delay-off feature and its sensitivity can be adjusted, but it requires a power input and costs more. The BD20 is less costly, smaller footprint, and does not absolutely require a power input (though it is strongly recommended to power it), but it is also less reliable and less sensitive.
- Power NCE BD20 current detectors with its rated power voltage (e.g. tap into the Accessory Power Bus) to enable operation of its status LED. This will assist in debugging the signal system during Free-mo setups.
- On NCE BD20 current detectors, loop the track feeder wire through the sensing transformer as many times as possible to increase its sensitivity. Two to four loops is typical.
- For infrared/optical detectors, NorCalF has traditionally used Heathcote Electronics IRDOT-1D board with an Optek Technology OPB704W or OPB705W track-mounted sensor. However, this combination can suffer false detections under certain lighting conditions. Iowa Scaled Engineering offers an optical detector/sensor that shows promise for solving this deficiency.
- Use Velcro or some other non-permanent attachment method to mount the required RJ45 female-female coupler inside each module endplate. Avoid gluing the couplers permanently in place. This method allows inspection, repair, and replacement of the coupler.
- Verify that each CAT5 cable segment of the MSS Occupancy Bus is properly constructed before installing it into the module. Use an appropriate RJ45 cable tester to confirm all eight conductors have continuity through the cable in the desired pattern (either crossover or straight through).
- Before each setup, inspect all RJ45 jacks, especially the endplate jacks, for damage to the embedded wiper contacts and repair as needed. These spring contacts can be damaged (bent, skewed, flattened, twisted, etc.) if a cable is inadvertently mis-connected during setup.

The following diagrams show typical MSS implementations for both types of modules.

Modular Signal System Typical MSS Crossover Module Electronics and Wiring

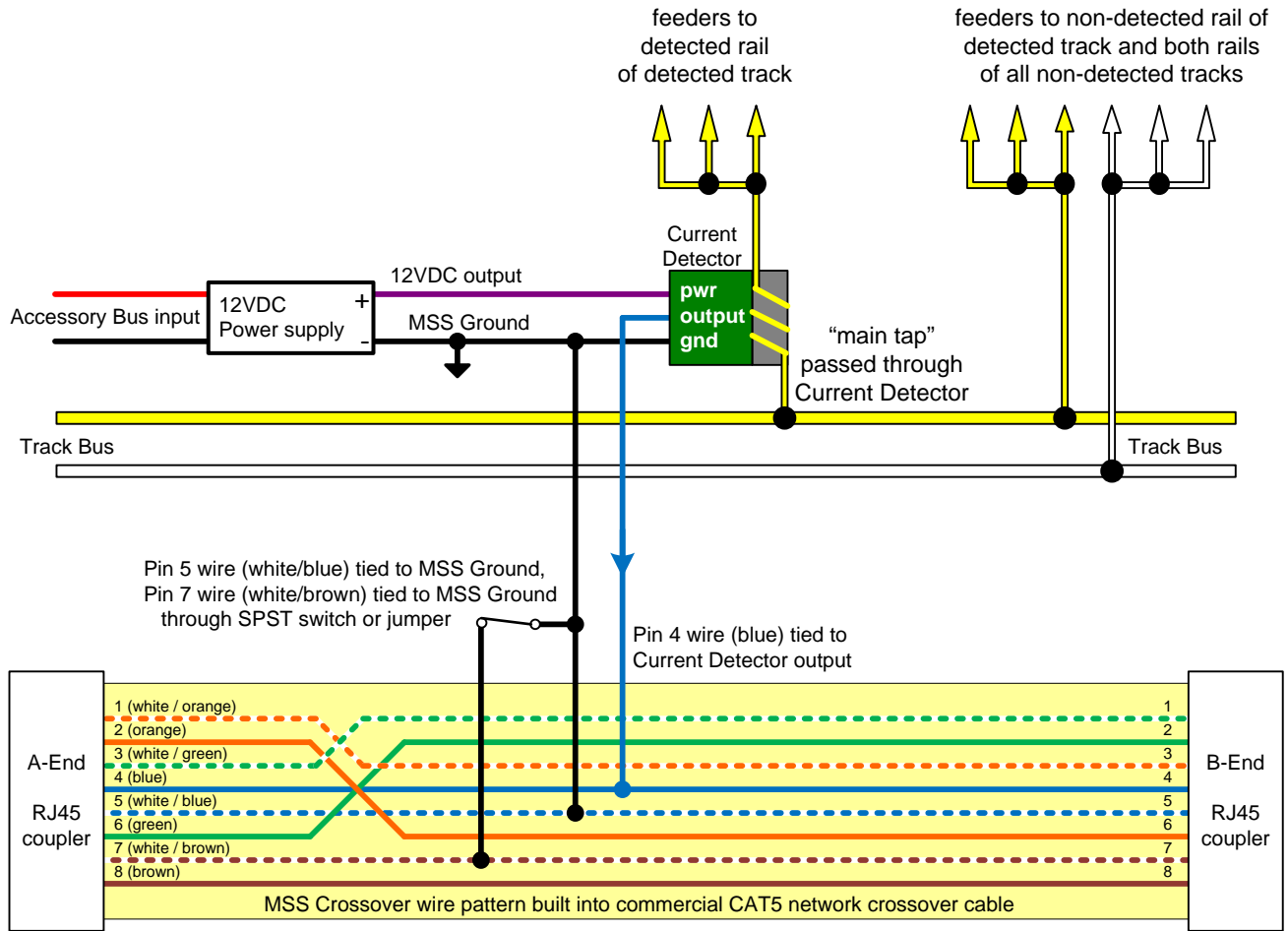

Modular Signal System

Typical MSS Cascade Module

Electronics and Wiring

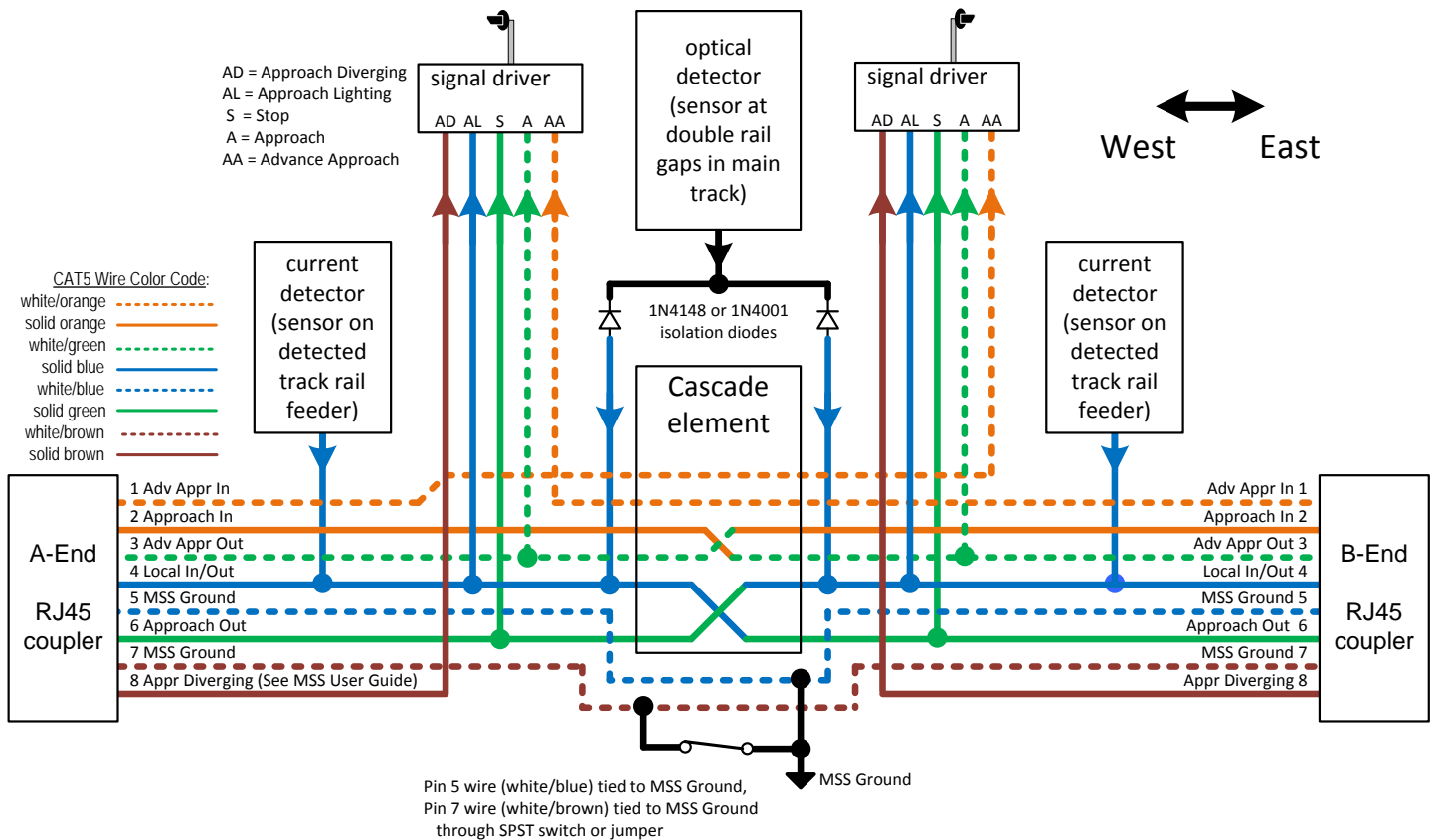

5.0 CONTROL

NorCalF has developed a robust method to configure Digitrax DCC systems in Free-mo layouts, detailed in a separate document “NorCalF DCC Standard” [S5.1].

All turnouts must be controlled locally (e.g. fascia buttons, hand throw levers, etc.), but also may be controlled through DCC. While the method of throw (powered or manual) is free, controls for all turnouts must be located on all operator-accessible sides of the module [S5.2]. Turnout controls must be placed to avoid the need for reaching into a module (e.g. Caboose Industries throws) [RP5.2.1].

Notes:

- DCC stationary decoders are allowed for turnout control as long as there is at least one other method, local to the module, available to throw the turnout (e.g. fascia buttons, hand throw levers, etc.). DCC decoder addresses must be registered in the DCC Address and Loco Roster file on the NorCalF Yahoo group to avoid duplications.

6.0 SCENERY

SCENERY STYLE, MATERIALS, TECHNIQUES

Scenery must depict realistic, commonly found rail-oriented scenes, with prototype locations preferred. Materials and techniques are free.

Suggestion: use a generic "Northern California" scenic theme so NorCalF layouts look continuous and integrated.

Scenery must allow hand-cleaning of rail on all active tracks. Refer to section 3.0 Track, Rail for rail cleaning constraints.

MAIN TRACK BALLAST

Ballast size must be "fine", such as Arizona Rock & Mineral 130-2 "Northern Pacific Medium Gray Granite HO Fine" or Woodland Scenics B1393 "Gray Blend Fine" (shaker bottle). Modules 12 feet or longer may use other ballast colors (to match a prototype locale, for example), but must gradually transition to the standard ballast at module ends [S6.4].

END PROFILE AND LANDSCAPE

A flat horizontal scenery profile is used at module ends with scenic "ground level" at module ends nominally 3/8" below top of rails [S2.2, S2.3]. Landscaping along the module ends must be designed to smoothly flow into adjacent modules - avoid features such as roads, lakes, and so forth terminating along the module endplates (see INTER-MODULE JOINT TREATMENT, below). Rather, terminate such features along the module sides.

Note: scenic contours within a module are free between the flat end profiles (i.e. entire module does not have to be flat; in fact table-top flat modules are discouraged).

INTER-MODULE JOINT TREATMENT

Polyfiber covered with fine ground foam (i.e. Woodland Scenics "turf" material) to simulate undergrowth "thickets" may be temporarily placed over joints during a NorCalF setup, in random patterns, shapes, and colors. This technique hides the joints and transitions scenery from module to module. Polyfiber thickets must be placed clear of the track right-of-way.

BACKDROP

No backdrop is allowed as modules are viewed from either side and are also meant to be reversible [S2.11].

7.0 PUBLIC DISPLAYS

This section contains NorCalF specific requirements and does not correlate to the general Free-mo standard.

SKIRTING

Both sides of all modules must have a skirt for use at public displays, to hide the legs and pigtail connections. NorCalF will provide embossed vinyl sheeting, 54" size, brown color, treated with Antimony Oxide to meet NFPA 701 (Rev. 1989) and California Fire Marshall flammability test. Each end of skirt extends 2" past the module endplate to ensure adequate coverage and no "gaps" at module joints. Bottom edge of skirt is even with bottom of leg vertical member to prevent dragging on the floor regardless of the module height setting. Skirt attaches to inside of fascia or to underside edge of fascia (the extra height of the 54" skirting material is folded inward at top of skirt to be hidden behind skirt face). It is not permitted to simply thumbtack skirting to the outside surface of the fascia as this method has a sloppy appearance and defaces the fascia with pinholes.

See Appendix B for a tutorial on making skirting with Velcro attachment.

CROWD CONTROL BARRIER SYSTEM

Each module that is five feet or longer must provide two barrier stands for every five feet of length. Barrier stands consist of bases and uprights designed for simple assembly and setup, and may be disassembled for more efficient storage and transport. 1/4-inch yellow nylon style ropes (available at any hardware store) are threaded through the stands as a barrier to prevent public access to the modules and trains.

Stand bases are 12" square made from either 1" or 1.5" plywood (or equivalent multiple plywood layers). Painting is optional. A hole is centered in the base to accommodate a 1/2-inch white PVC pipe end cap, firmly wedged into the hole and used to receive the stand upright.

Stand uprights press-fit into the base and are 36" tall 1/2-inch white PVC pipe with a PVC "T-junction" mounted on top, through which the nylon rope is threaded. Painting is not allowed – leave uprights white.

PLEXIGLAS SHIELDS

Free, but must be easily removable for access to track for cleaning, uncoupling cars, repairing scenery, etc.

8.0 LOCOMOTIVES AND ROLLING STOCK

This section contains NorCalF specific requirements and does not correlate to the general Free-mo standard.

WHEELS

- Metal
- Clean
- Back-to-back spacing meets NMRA gauge
- Gauge meets NMRA gauge
- Flange contours are RP-25 or have equivalent flange depth
- Semi-scale (.088") wheel treads are allowed

ROLLING QUALITY

- Cars roll freely down a 3% grade

TRUCKS

- Pivot freely
- Slight lateral rock on at least one end (three-point mount)
- Able to negotiate a #5 turnout
- Able to negotiate a 30" radius curve
- Able to negotiate vertical rail curves and super-elevations

COUPLERS

- Kadee #5 or #58; no substitute brands allowed as they all have one problem or another
 - Match to center of Kadee coupler height gauge or NMRA Standards Gauge, plus or minus 1/32"
 - Knuckle and centering springs work freely
 - Free of flash
 - Metal couplers are insulated from the rail
 - Trip pins clear Kadee coupler height gauge or equivalent
- OPTIONAL: coupler trip pins may be cut off at the bottom of the coupler body

WEIGHT

- Weighted to within +10%, -5% of NMRA specification (1 oz + ½ oz for each inch of car length):

car length (scale ft)	NMRA weight (oz)
30	3.1
35	3.4
40	3.8
45	4.1
50	4.4
55	4.8
60	5.1
65	5.5
70	5.8
75	6.2
80	6.5
85	6.9
90	7.2

NOTE: Cars operated only in unit trains may be weighted less or more than specified.
Such cars may not be operated in other trains.

ELECTRONICS

- Locomotives equipped with DCC decoders compatible with NMRA DCC compliant systems.
- Locomotives use 4-digit address—address is locomotive road number.
- Analog conversion (DC operation) must be disabled to prevent runaways.
- Register decoder addresses (rolling stock and stationary) on the NorCalF Address List to avoid duplications.

9.0 SETUP CHECKLIST

This section contains NorCalF specific requirements and does not correlate to the general Free-mo standard.

REQUIRED ITEMS

In addition to the obvious items such as modules, legs, and rolling stock, the following items are required for participants to bring to a Free-mo setup:

- ❑ For each module, minimum of two 2" fitter rails with one metal joiner and one insulating joiner, for each track crossing module joints. Additional fitter rails are always welcome. Bring additional fitter rails and joiners to connect any additional tracks that cross module joints (i.e. yard extension modules). Atlas makes a metal joiner that fits both code 83 and code 100 rail; these seem to work well for fitter rails as they can be pushed easily onto the module's permanent rail ends with a small screwdriver. Atlas also makes code 83 insulated clear-plastic joiners, which are recommended.
- ❑ For each module, minimum of one large C clamp to hold module ends together. Deep-throated clamps are best.
- ❑ For each module, minimum of one 36" six conductor phone cable with RJ12 clip plugs on both ends, wired straight through, to connect the Digitrax DCC LocoNet across module joints.
- ❑ For each module, minimum of one 36" CAT5 "Ethernet" cross-over cable to connect the Occupancy bus across module joints.
- ❑ Digitrax DCC booster – each participant who has a module in the layout shall bring at least one booster that is configured in the standard NorCalF way (refer to "NorCalF DCC Standard").
- ❑ Digitrax DCC throttle – each participant who plans to operate trains at a Free-mo setup shall bring at least one throttle, whether they have a module in the layout or not. Extra throttles are rarely available to borrow.
- ❑ For each module with a self-contained power supply, AC power extension cords, outlet strips, and outlet expanders. Do not rely on others to provide power distribution to your module.
- ❑ Skirting for all viewable module sides, when required by the Run Chief.
- ❑ Barrier stands and nylon ropes, when required by the Run Chief (two stands for every five feet of module length).
- ❑ Optional: polyfiber/ground foam "thickets" to cover inter-module joints on both sides of main line.

RECOMMENDED ITEMS

Other items recommended to bring, but not required:

- ❑ Extra AC power extension cords, outlet strips, and outlet expanders to distribute wall power throughout the layout.
- ❑ FRS 14-channel radios – handy for operations in noisy show environments.
- ❑ Spare batteries and/or rechargers for throttles, radios, tools.
- ❑ Tools including rail cutters, files, wood glue, levels, wrenches, screwdrivers, tape measures, pliers, wire cutters and strippers, multi-meter, soldering iron, track gauge, rail cleaning abrasive block and/or alcohol, etc. These help resolve problems that may crop up, and to repair minor damage that may occur while transporting modules.
- ❑ Model tools including coupler height gauge, wheel gauge, small screwdrivers, ACC and styrene glues, tweezers, files, etc. These help repair or adjust rolling stock and track to keep things running smoothly.
- ❑ Spare parts and scenic supplies for repairing trains and modules.
- ❑ Lamps or flashlights to inspect module undersides.
- ❑ Folding chair or stool.

APPENDIX A: LEGACY ELECTRICAL GUIDELINES PRIOR TO JULY 2015

By July 1, 2016, all modules must be converted to Anderson PowerPole connectors for the Track Power and Accessory Power bus pigtails, and must have the DCC Booster Commons bus and pigtails installed.

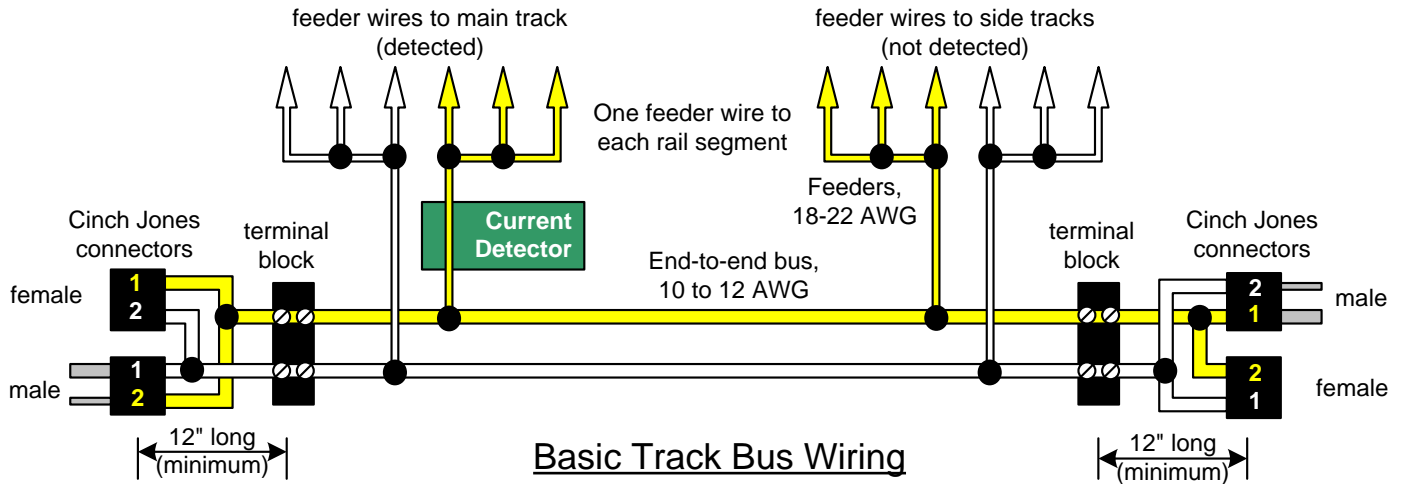

The Track Power Bus had two Cinch "jones" connectors at each end of each module. The two connectors formed a male and female pair, cross-wired to allow a module to be rotated (reversed) and still maintain correct track polarity. These "pigtails" were 12" long minimum and terminated within 6" of module endplates, using 12-16 AWG stranded wire.

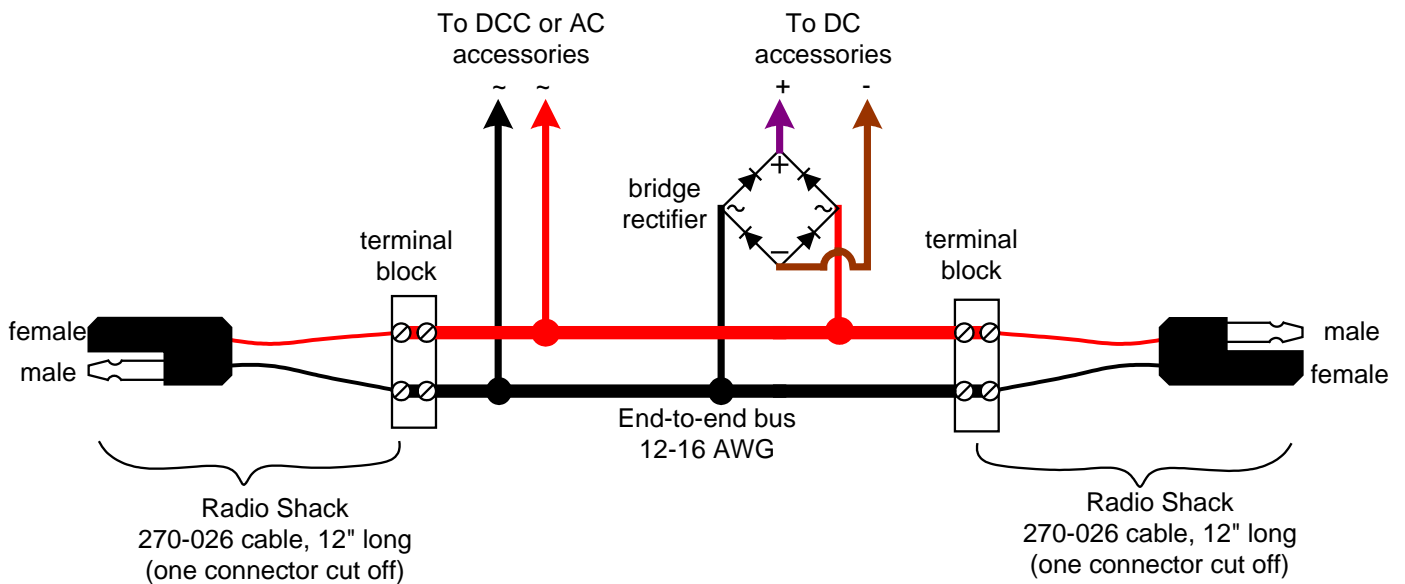

The Accessory Power Bus had 12" long minimum pigtails made from "automotive DC accessory cable" connectors, often called "trailer plugs", terminating within 6" of module endplates. The internal module wiring used 12-16 AWG wire.

APPENDIX B: TUTORIAL FOR VELCRO-ATTACHED VINYL SKIRTING

NorCalF requires brown vinyl skirts for all visible sides of each module so that NorCalF layouts present a consistent and finished appearance at public shows. These vinyl skirts must travel with their modules, are reusable, and can be easily replaced if lost or damaged.

NorCalF has a supply of fire-retardant embossed vinyl sheeting (in rolls), available for distribution to module owners for making skirts as described here. It was originally purchased from Exclusively Expo:

<http://www.exclusivelyexpo.com/>

STEP 1: SKIRT HORIZONTAL LENGTH

The horizontal length of each skirt is determined by the length of the module side to which it is attached, plus an additional 4" to 6". The added length allows the skirt to extend 2" to 3" past the module's endplates, such that it overlaps the adjacent module's skirt to prevent unsightly gaps in the layout's skirting.



Measure the appropriate length of skirting vinyl and cut it from the roll. Be careful to cut the vinyl at a 90-degree angle to its edge to get a rectangular skirt (and not a trapezoid).

STEP 2: MODULE VELCRO



Attach 2" (minimum) lengths of beige sticky-back Velcro "hook" to the bottom edges of the module's fascias (side frames). Place Velcro pieces at both ends of the fascia, within 1" of each endplate, and additional pieces spaced 9" to 12" along the module to adequately support the skirt with minimal sag, etc.

Once the Velcro "hook" pieces are located properly, staple them onto the module's fascia bottom edge to ensure they stay in place over time.

STEP 3: SKIRT HEIGHT AND SKIRT VELCRO



Matching 2" (minimum) lengths of beige sticky-back Velcro "loop" (upper left) are installed on the skirt's "outer" (visible) side, stiffened by small wooden blocks on the "inner" (non-visible) side (upper right). Wooden paint stirring sticks (available for free from hardware store paint departments) are a good source for the wood stiffening blocks; these can be cut down to size as needed.

Note the label (lower right) identifying the skirt's module and position. Another method is to write directly on the vinyl with a black Sharpie. Place this marking on the "inner" side so it is not visible when the skirt is attached.

The vertical location of the Velcro/wood on the vinyl skirt depends on the height of the module's fascia bottom edge from the floor (which varies from module to module due to differences in frame construction); this location is critical as it establishes the height of the skirting when attached to the module. As shown below, locate the Velcro/wood such that the bottom edge of the finished skirt is at the bottom of the module's vertical leg member, not including the adjustable-height foot. This ensures the skirt does not drag on the floor regardless of the module's height setting. Some amount of "gap" will be present between the floor and the skirt, which is expected.



Carefully align the Velcro "loop" pieces left/right with the Velcro "hook" installed on the module in Step 2. Once the proper vertical location and left/right alignment are achieved, staple the Velcro "loop" through the vinyl into the wood stiffening blocks. This is necessary because the sticky-back Velcro does not permanently stick to the vinyl.

STEP 4: SKIRT ATTACHMENT

Attaching the skirt to its module for a setup is a simple matter of aligning the Velcro "loop" on the skirt to the Velcro "hook" on the module fascia and pressing them together.

The 54" vertical size of the vinyl results in some extra skirt "height" - this is folded over at the top and hidden behind the skirt itself. The weight of this extra material actually helps "balance" downward forces on the Velcro, preventing it from sagging to one side.



The completed skirt gives the module a finished look, compared to the "bare" module to the left. With skirts attached to both sides, the space beneath the module is enclosed and provides a place to store equipment, tools, trains, etc. out of public view. And, since the skirts are attached only at the top, they can be easily lifted to duck under the layout.



For storage and transport, neatly fold the skirts with their location markings visible and keep them in a bag or box.



REVISION HISTORY

05/2016	In section 4.2, added LocoNet throttle jack orientation requirement
02/2016	Updated section 4.5, MSS Occupancy Bus and MSS wiring drawings
11/2015	Minor update.
07/2015	general update; renumbered and renamed sections to match general Free-mo standard; removed duplicate requirements that are in the general Free-mo standard; added references to related requirements in general Free-mo standard; conversion to Anderson Power Pole connectors including new DCC Booster Commons bus; updated MSS drawings and ground system; added Appendix A for legacy Cinch Jones connectors; add Appendix B for vinyl skirts.
12/2008	general update; added detection and occupancy information.
6/2002	added double track standards, general update reflecting current construction methods.
12/2000	added skirting and barrier requirements, general update, converted to PDF for web viewing/printing
8/29/2000	added rolling stock section; clarified vertical curves, general update
8/7/2000	updated sketches, tightened up spec of endplates, leg heights, track; added more suggestions for reliability
7/7/2000	changed group name to Northern California Free-mo, minor text improvements
6/7/2000	Added fascia labeling guidelines, revised Accessory bus to allow DCC, corrected fonts
11/10/1999	improved sketches, minor text changes
5/2/1999	added Accessory Power bus; updated DCC info; enlarged min radius to 42"; replaced Timescape paint with Great Desert
10/6/1998	added DCC and setup guidelines
9/30/1998	general update; added scenery guidelines; changed sketches to Visio
5/4/1998	general update